

Configuration		
Safety	Steering deceleration	●
	Rear handle with horn for truck reversing	●
	Overspeed alarm (5km/h)	○
	Overspeed alarm(8km/h)	○
	Overspeed alarm (10km/h)	○
	Speed limit ((no ultimate limit type)	○
	Full set of OPS	●
	Safety switch for seat belt	○
	Hydraulic valve overload protection device	●
	Dry powder extinguisher (0.5kg)	○
	Dry powder extinguisher (2kg)	○
	Backward buzzer	○
	Reversing speaker (Chinese)	●
	Electronic upper buffering	●
	Wide- angle central rear view mirror	●
Rearview mirror on two sides+ Center wide angle rearview mirror	○	
Comfort	Semi-enclosure seat	●
	Full suspension seat	○
	1 USB interface (5V/1A)	●
	Super low torque steering unit	●
	Mechanical control valve	●
Cab/Windshields	Fan	○
	Panel mounted cab	○
	With heater and air conditioner for cooling	○
	Front windshield	○
	Rear windshield	○
Lingts	Top windshield	○
	LED rear working lamp (two)	○
	Rear LED red/blue spot lamp	○
	Left, right and rear blue bar	○
	Fixed type LED flicker warning lamp	●
Others	Fixed type LED rotating warning lamp	○
	Fixed type LED rotating buzzer warning lamp	○
	Sleeve for steering cylinder	●
	Sleeves for steering cylinder and tilting cylinder	●
	FICS standard type (domestic)	●

Note: "●" standard; "○" optional;

CHL PREMIUM

CPD 60/70
A11LIG2-H
CPD 85/100
A11LIG2-M



LITON 6-10 t
G2 Series Lithium-ion Battery
Forklift Truck

INNOVATIVE INTEGRATION CONCEPT LITHIUM LEADS THE FUTURE

CHL PREMIUM

FULL OF POWER



INTEGRATED DRIVE SYSTEM

Powerful, safe and reliable



HIGH-EFFICIENCY LIQUID-COOLED PERMANENT MAGNET SYNCHRONOUS SYSTEM

High efficiency, low energy consumption,
Satisfying heavy working conditions and
High-intensity continuous operation



HIGH PROTECTION PARTS HIGH CHASSIS HIGH LOAD CAPACITY PNEUMATIC TIRES

Adapt to complex environment operations



SUPER FAST CHARGE

Effectively improve operation time,
Adapt to new energy vehicle charging pile

PRODUCT CHARACTERISTICS



A new generation design of the hidden rubber hose pulley block of the mast, wide view ahead

COMFORTABLE DRIVING, SAVE WORRY AND EFFORT

- Ergonomic forward design, More comfortable driving.
- Standard, imported, silent, hydraulic pump, Effectively improve the driving comfort.



SMART SECURITY COMPREHENSIVE PROTECTION

- High and low voltage independent power distribution, Safer Easier to maintain.
- Independent driving brake Safe and Reliable, Energy-saving and efficient.



External service switch Easy to operate Effectively prevent electrified misoperation

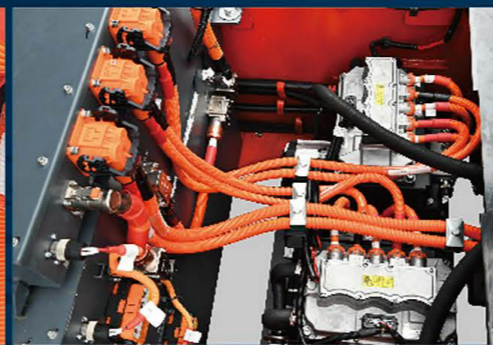

Dedicated high voltage orange cable meet the standards of new energy vehicles, multi-layer protection, wear-resistant, eye-catching



Standard mast up and down buffer, avoid extreme impact, intelligent safety

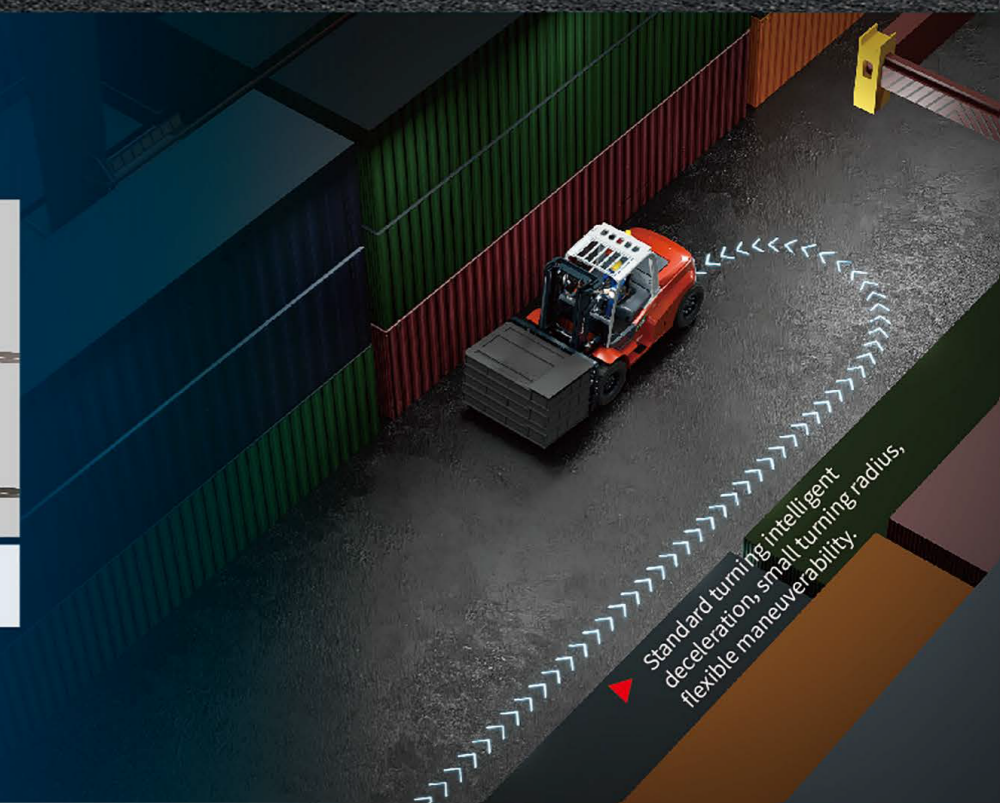

Standard turning, intelligent deceleration, small turning radius, flexible maneuverability.

EFFICIENT OPERATION, YIELD TWICE THE RESULT WITH HALF THE EFFORT

- Fast lifting speed, High loading and unloading efficiency.
- Optimize vehicle structure design, Higher carrying capacity. Easily cope with various heavy-duty job demands.

INDEPENDENT RESEARCH AND DEVELOPMENT, STABLE AND RELIABLE

- The whole machine frame, overhead guard, door frame mast, etc. have been analyzed and designed through CAE forward analysis, safe and reliable.
- Machine rain test, Bumpy road test, multiple rigorous tests, the protection level reaches IP67.
- The key core components and parts have been tested by high strength experiment.



EASY MAINTENANCE, RELAXED



Integrated electrical cabinet, embedded instrument, easy to disassemble and maintain



Integrated hydraulic cabinet, Easy maintenance of braking system



Open the hood at a wide angle. Detachable front and rear baseplate. Easy to check, replace and repair.

PERSONALIZED CUSTOMIZATION, RICH CONFIGURATION

The vehicle can be equipped



Solid tire



Lighting



Reversing image



Thumb switch



Autonomous system Weide system



Dual power system, can meet different options



Manufacturer and Technical Data		CHL PREMIUM					
Manufacturer		CPD60	CPD70	CPD85	CPD100		
1.01	Model	CPD60	CPD70	CPD85	CPD100		
1.02	Configuration number	A11LIG2-H	A11LIG2-H	A11LIG2-M	A11LIG2-M		
1.03	Rated capacity	6000	7000	8500	10000		
1.04	Load center distance	Q	kg	600	600		
1.05	Powermode	Lithium battery					
1.06	Driving mode	Seated					
1.07	Front overhang	x	mm	580	585	687	702
1.08	Wheelbase	y	mm	2300	2500	2775	
Weight							
2.01	Total weight (with/without battery)	kg	8750/8130	9365/8745	11600/10860	12720/11980	
2.02	Axle load (laden, front/rear)	kg	13390/1360	14770/1595	18300/1800	20750/1970	
2.03	Axle load (unladen, front/rear)	kg	4310/4440	4165/5200	5400/6200	6055/6665	
Tyres							
3.01	Tyre type	Pneumatic tyre					
3.02	Tyre size, front	8.25-15-14PR		9.00-20-14PR			
3.03	Tyre size, rear	8.25-15-14PR		9.00-20-14PR			
3.04	Wheels, number front/rear (x=driven wheels)	4 x 2					
3.05	Tread, front	b ₁₀	mm	1520	1600		
3.06	Tread, rear	b ₁₁	mm	1700			
Dimensions							
4.01	Mast tilt angle (forward/backward)	α/β	°	6/12			
4.02	Height (mast lowered)	h ₁	mm	2480	2700	2850	
4.03	Free lifting height	h ₂	mm	160	165	190	200
4.04	Lifting height (standard)	h ₃	mm	3000			
4.05	Max. height, extended (with backrest)	h ₄	mm	4400	4250	4415	
4.06	Height of overhead guard	h ₅	mm	2450		2560	
4.07	Seat height relating to SIP (to ground)	h ₇	mm	1435		1540	
4.08	Towing coupling height	h ₁₀	mm	535		600	
4.09	Overall length (with fork)	l ₁	mm	4795	4865	5172	5422
4.10	Overall length (without fork)	l ₂	mm	3575	3645	3952	4202
4.11	Overall width	b ₁	mm	2045			
4.12	Fork size: thickness x width x length	s/e/l	mm	60 x 150 x 1220	65 x 150 x 1220	70 x 175 x 1220	80 x 175 x 1220
4.13	Fork carriage, according to ISO2328			4A			
4.14	Distance across fork-arms, Max./Min.	b ₃	mm	1845/300	1990/470	2100/470	
4.15	Distance across fork-arms, Max./Min.	m ₁	mm	180		250	
4.16	Ground clearance (center of wheelbase)	m ₂	mm	230		325	
4.17	Right angle stacking aisle width for pallet 1200 x 1200mm crossways	A ₂	mm	5060	5125	5517	5842
4.18	Right angle stacking aisle width for pallet 800 x 1200mm lengthways	A ₃	mm	5260	5325	5717	6042
4.19	Min. outside turning radius	W ₃	mm	3280	3340	3630	3940
Performance Data							
5.01	Travel speed (laden/unladen)	km/h	25/25	25/25	20/20	20/20	
5.02	Lift speed (laden/unladen)	mm/s	425/460	365/460	425/460	350/380	
5.03	Lowering speed (laden/unladen)	mm/s	Without load ≥ 300 / with full load ≤ 600				
5.04	Max. drawbar pull (laden)	N	47000	47000	55000	55000	
5.05	Max. gradeability (laden/unladen)	%	25/25	25/25	20/20	20/20	
5.06	Acceleration time (10 m) (laden/unladen)	s	5.2/4.9	5.2/4.9	5.4/5	5.6/5.2	
Battery							
6.01	Battery voltage/Capacity	V/Ah	326.4/150	326.4/150	326.4/202	326.4/202	
6.02	Battery weight	kg	620	620	740	740	
Motor and controller							
7.01	Driving motor powering (S2-60min)	kW	50				
7.02	Lifting motor powering (S3-15%)	kW	30x2				
7.03	Driving motor controlling mode		MOSFET/AC				
7.04	Lifting motor controlling mode		MOSFET/AC				
Addition data							
8.01	Service brake / Parking brake		Hydraulic/mechanical				
8.02	Relief pressure	Mpa	14				

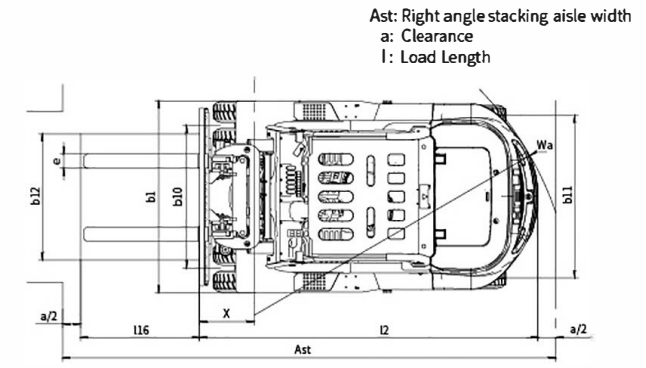
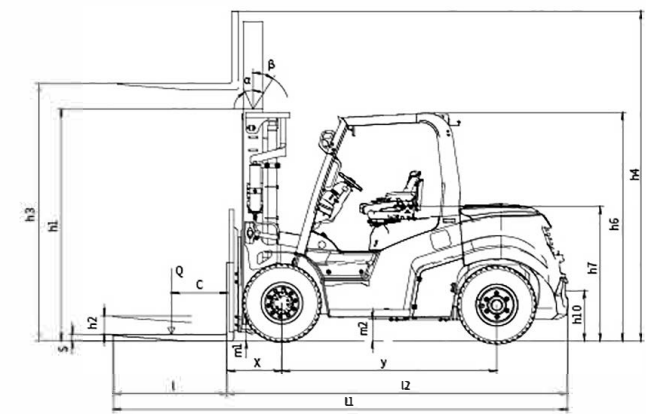

Ast: Right angle stacking aisle width
a: Clearance
l: Load Length

6-7t Wide View Standard Mast

Mast model	Max.lifting height (mm)	Load capacity (lode center 600mm)(kg)		Height (mast lowered)(mm)	Service weight (kg)		Mast tilt angle α/β (°)
		CPD60	CPD70		CPD60	CPD70	
M200	2000	6000	7000	2080	8650	9260	6/12
M250	2500	6000	7000	2230	8670	9280	6/12
M270	2700	6000	7000	2330	8690	9300	6/12
M300	3000	6000	7000	2480	8750	9365	6/12
M330	3300	6000	7000	2630	8790	9400	6/12
M350	3500	6000	7000	2730	8820	9430	6/12
M375	3750	6000	7000	2855	8865	9475	6/12
M400	4000	6000	7000	3030	9030	9640	6/12
M425	4250	6000	7000	3155	9070	9680	6/12
M450	4500	6000	7000	3280	9110	9720	6/12
M475	4750	6000	7000	3405	9150	9760	6/6
M500	5000	6000	7000	3530	9190	9800	6/6
M550	5500	5700	6600	3830	9385	9995	6/6
M600	6000	5400	6400	4080	9465	10075	6/6

6-7t Wide View Full Free 2-Stage Mast

Mast model	Max.lifting height (mm)	Load capacity (lode center 600mm)(kg)		Height (mast lowered) (mm)	Free lift (with backrest) (mm)	Service weight (kg)		Mast tilt angle α/β (°)
		CPD60	CPD70			CPD60	CPD70	
ZM250	2500	6000	7000	2210	840	8780	9390	6/12
ZM270	2700	6000	7000	2310	940	8815	9425	6/12
ZM300	3000	6000	7000	2460	1090	8875	9485	6/12
ZM330	3300	6000	7000	2610	1240	8930	9540	6/12
ZM350	3500	6000	7000	2710	1340	8970	9580	6/12
ZM375	3750	6000	7000	2835	1465	9015	9625	6/12
ZM400	4000	6000	7000	3010	1640	9190	9800	6/12
ZM425	4250	6000	7000	3135	1765	9245	9855	6/12
ZM450	4500	6000	7000	3260	1890	9285	9895	6/12
ZM475	4750	6000	7000	3385	2015	9335	9945	6/6
ZM500	5000	6000	7000	3510	2140	9370	9980	6/6
ZM550	5500	5700	6600	3810	2440	9590	10200	6/6
ZM600	6000	5400	6400	4060	2690	9685	10295	6/6

Note: (1) 6t: the free lift without backrest 260mm increased, (2) 7t: the free lift without backrest 180mm increased.

6-7t Wide View Full Free 3-Stage Mast

Mast model	Max.lifting height (mm)	Load capacity (lode center 600mm)(kg)		Height (mast lowered) (mm)	Free lift (with backrest) (mm)	Service weight (kg)		Mast tilt angle α/β (°)
		CPD60	CPD70			CPD60	CPD70	
ZSM360	3600	5600	6200	2335	910	9325	9935	6/6
ZSM400	4000	5600	6200	2460	1040	9385	9995	6/6
ZSM435	4350	5600	6200	2585	1156	9440	10050	6/6
ZSM480	4800	5600	6200	2740	1310	9640	10250	6/6
ZSM500	5000	5600	6200	2805	1380	9670	10280	6/6
ZSM540	5400	5300	6000	2940	1510	9740	10350	6/6
ZSM600	6000	5000	5600	3135	1710	9830	10440	6/6
ZSM650	6500	4500	5000	3405	1975	9915	10525	6/6
ZSM700	7000	4000	4500	3510	2085	9970	10580	6/6

Note: (1) 6t: the free lift without backrest 260mm increased, (2) 7t: the free lift without backrest 180mm increased.

Load curve

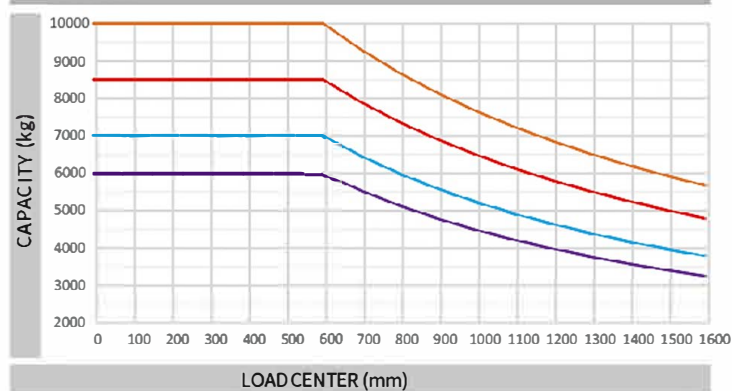

Note: The vertical axis stands for load capacity and the horizontal axis stands for load center which is calculated from the front surface of the forks to the gravity of the standard load. the standard load means a cubic with 1000mm edge length. When mast is tilted forward, using non-standard forks or loading large goods, the load capacity will be reduced. The load capacity of standard mast at different load center can be known from this load chart.

8.5-10t Wide View Standard Mast

Mast model	Max.lifting height (mm)	Load capacity (lode center 600mm)(kg)		Height (mast lowered)(mm)		Service weight (kg)		Mast tilt angle α/β (°)
		CPD85	CPD100	CPD85	CPD100	CPD85	CPD100	
M250	2500	8500	10000	2450	2600	10920	12610	6/12
M270	2700	8500	10000	2550	2700	10975	12650	6/12
M300	3000	8500	10000	2700	2850	11600	12720	6/12
M330	3300	8500	10000	2850	3000	11700	12780	6/12
M350	3500	8500	10000	2950	3100	11845	12825	6/12
M375	3750	8300	10000	3075	3225	11925	12875	6/12
M400	4000	8300	10000	3250	3400	12100	13015	6/12
M425	4250	8000	10000	3375	3525	12255	13070	6/12
M450	4500	8000	9000	3500	3650	12375	13120	6/12
M475	4750	8000	9000	3625	3775	12520	13175	6/6
M500	5000	7800	9000	3750	3900	12635	13230	6/6
M550	5500	7500	8000	4050	4200	12960	13535	6/6
M600	6000	7200	7500	4300	4450	13160	13585	6/6

8.5-10t Wide View Full Free 3-Stage Mast

Mast model	Max.lifting height (mm)	Load capacity (lode center 600mm)(kg)		Height (mast lowered)(mm)		Free lift (with backrest) (mm)		Service weight (kg)		Mast tilt angle α/β (°)
		CPD85	CPD100	CPD85	CPD100	CPD85	CPD100	CPD85	CPD100	
ZSM360	3600	7500	8000	2450	2570	1200	1150	12240	13470	6/12
ZSM400	4000	7500	8000	2575	2700	1330	1280	12310	13560	6/12
ZSM435	4350	7400	7800	2700	2820	1450	1400	12385	13640	6/12
ZSM450	4500	7300	7800	2750	2870	1500	1450	12415	13680	6/6
ZSM480	4800	7000	7300	2850	2970	1600	1550	12475	13750	6/6
ZSM500	5000	7000	7300	2950	3035	1700	1615	12530	13795	6/6
ZSM540	5400	6600	6800	3075	3225	1830	1805	12605	13330	6/6
ZSM600	6000	5800	6000	3375	3425	2130	2005	12775	14250	6/6
ZSM650	6500	5300	5500	3600	3590	2350	2170	12905	14185	6/6
ZSM700	7000	4500	4600	3750	3855	2500	2435	12995	14365	6/6

Note: 8.5-10t: free lift without backrest.

Battery configuration

Model	Standard battery capacity	Optional battery capacity		
	HEDING	HEDING	HEDING	PENGCHENG
CPD60/70	326.4V/150Ah	326.4V/202Ah	326.4V/250Ah	/
CPD85	326.4V/202Ah	326.4V/250Ah	/	/
CPD100			336V/280Ah	/

Chargers

Charger model	D336V100AL1-425
rated input voltage	AC380V±15%
rated frequency	45HZ-60HZ
Input power	≤40KVA
Protection class	IP20
Rated output voltage	200V-500V
Rated output current	5A-100A
Rated output power	40KW
Cooling type	Forced cooling
Operating temperature	-20°C-50°C
Power plug	International universal charging plug
Model	CPD60/70-A11LIG2-H
	CPD85/100-A11LIG2-M
	CPD60/70-A6LIG2-H
	CPD85/100-A6LIG2-M