

CHL PREMIUM

CHL PREMIUM

**CPD15/18/20/25
/30/35/38**
A3LiH4-M A7LiH4-S A7XLiH4-S



1.5-3.8 t **LITHION**

H4 series Lithium-ion Battery
Forklift Truck



Lead & Lithium Are Ready To Go.

- / People oriented design concept
- / Inheritance family design concept
- / Seek breakthrough in a appearance
- / Showing dynamic charm in design details

Comfort and energy saving

01~02

The user experience is fully considered, and the superior operating space design provides high driving comfort.

Stable and Reliable

03~04

CAE analysis, component bench test and whole truck strengthening test are used to ensure reliability.

Intelligent security

05

Intelligent control and protection improve the safety of drivers.

Convenient maintenance

06

More convenient maintenance operation improves the maintenance efficiency of after-sale services.

Comfort and energy saving

The user experience is fully considered, and the superior operating space design provides high driving comfort.

Wide view mast design, wide front view

The big handle and the superspacious cab design are suitable for people of different heights.

Steering wheel start steering (optional)

P, E, S three speed regulation

- P — Powerful
 - E — Economics
 - S — Energy saving
- Multi gear performance mode can be freely selected according to actual working conditions.



The whole truck is equipped with LED lighting system as standard, with high brightness, long service life and more energy saving

Reversing horn handle (s optional, M standard)



Semi enclosed shock-absorbing seat offers high comfort.



Electric special pattern tyre has low driving damping.

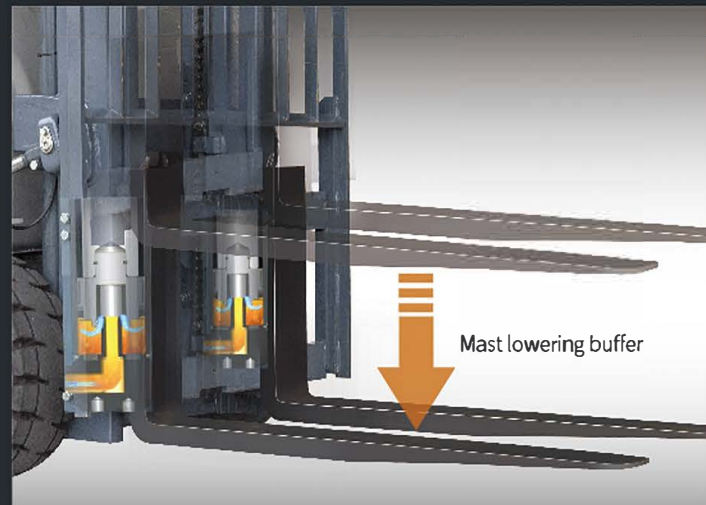

Mast lowering buffer

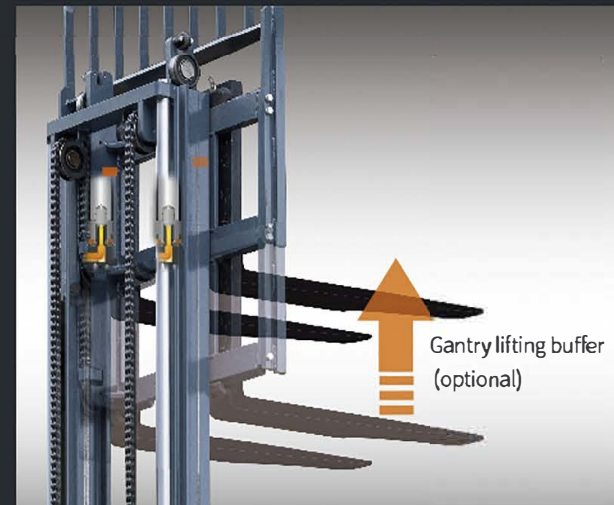

Gantry lifting buffer (optional)

Right set operating valve stem offers good operation comfort.

Intelligent color screen instrument offers more friendly human-computer interaction.



Graphical interface design / Chinese fault display / integrated handheld unit function / optional integrated vehicle networking function



Full package design of instrument panel; Water cup holder, mobile phone storage space, USB interface (optional for S, standard for M)

Stable and Reliable

CAE analysis, component bench test and whole truck strengthening test are used to ensure reliability.

Reliable components



Steering axle:
Cast axle body, tapered roller bearing

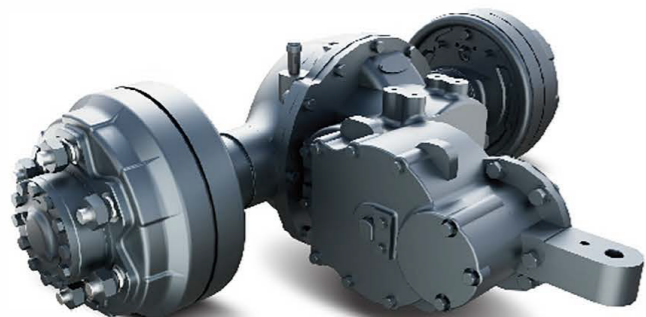

Drive axle:
integral brake drum, integral cast axle housing, half shaft oil seal design, high-precision gear with large coincidence



Mast:
Borrowing the main components of mature mast of internal combustion forklift truck

Sheet metal stamping side cover

All metal anti-skid pedal



Good lateral stability of the whole truck and guaranteed safety during operation

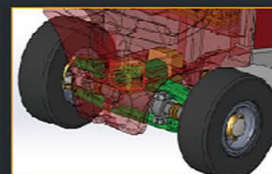

High rotation point steering axle

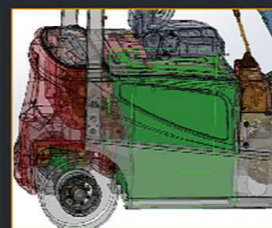

Middle and sink layout of the battery

Good heat dissipation

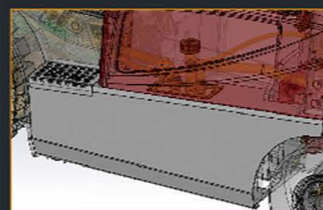

Side mounted welded oil tank



Test verification



Rain test

Simulate the operation under 15min rainstorm, reach IPx4 protection grade, and meet the needs of outdoor operation.



Cold storage test

The whole truck can run continuously after 6 hours of alternating operation in the -20 °C cold storage and 12 hours of parking in the cold storage.



Vehicle vibration test

The vibration frequency of the whole truck is tested to optimize and improve the operating comfort.



Reliability endurance test

800 hour strengthening of the whole truck (including climbing, rain, bumpy road, etc.).

Intelligent security

Intelligent control and protection improve the safety of drivers.

- Dual core controller
- OPS protection
(standard driving OPS / optional hydraulic OPS)
- Hydraulic burst protection, forward tilting self-locking protection
- Electrical multiple protection
(short circuit protection, overheat protection, low power protection, sequence protection)
- Parking safety reminder
- Reminder through slow sliding on ramp
- Turning automatic deceleration (optional)



- Flexible battery charging mode (can be charged with the truck or replaced)
- Pump, pump motor, controller and other main electrical components are located on the counterweight, which is convenient for maintenance.
- Friendly interface

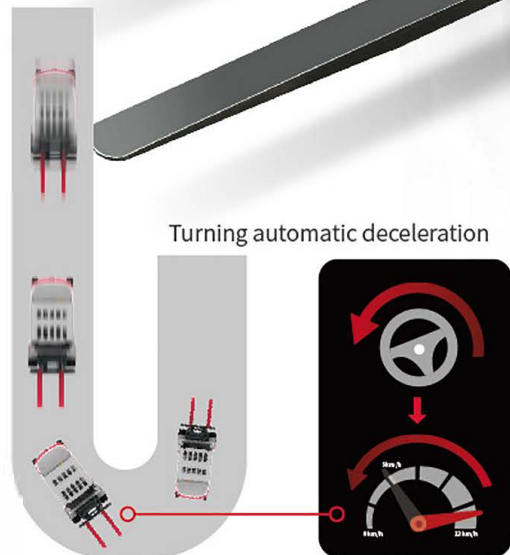

 **Driver Presence Sensing System** **Unmanned self-locking intelligent protection**

Convenient maintenance

More convenient maintenance operation improves the maintenance efficiency of after-sale services.

Manufacturer and Technical Data(Tabulation 1)

Characteristics		CPD15 CPD18 CPD15 CPD18 CPD20						
1.01 Manufacturer		CHL PREMIUM						
1.02 Model		CPD15		CPD18		CPD20		
1.03 Configuration number		A3LiH4-M		A7LiH4-S		A7XLiH4-S		
1.04 Rated capacity		Q	kg	1500	1800	1500	1800	2000
1.05 Load center distance		c	mm	500				500
1.06 Power mode		Lithium battery						
1.07 Driving mode		Seated						
1.08 Front overhang		x	mm	409		409		414
1.09 Wheelbase		y	mm	1475		1475		
Weight								
2.01 Total weight (with/without battery)			kg	2855/2675	2970/2790	2835/2672	2950/2787	3100/2920
2.02 Axle load (laden,front/rear)			kg	3719/636	4203/567	3711/624	4196/555	4547/553
2.03 Axle load (unladen,front/rear)			kg	1294/1561	1293/1677	1287/1548	1286/1664	1308/1792
Tyres								
3.01 Tyre type		Pneumatic tyre			Pneumatic tyre			
3.02 Tyre size,front		6.50-10-10PR			6.50-10-12PR			
3.03 Tyre size,rear		16×6-8-10PR			16×6-8-10PR			
3.04 Wheels, number front/rear (x=driven wheels)		2/2			2/2			
3.05 Tread, front		b10	mm	934			934	
3.06 Tread, rear		b11	mm	920			920	
Dimensions								
4.01 Mast tilt angle (forward/backward)		α/β	°	6/8			6/8	
4.02 Height (mast lowered)		h1	mm	1995			1995	
4.03 Free lifting height		h2	mm	155			155	
4.04 Lifting height (standard)		h3	mm	3000			3000	
4.05 Max. height, extended (with backrest)		h4	mm	4014			4014	
4.06 Height of overhead guard		h6	mm	2130			2130	
4.07 Seat height relating to SIP (to ground)		h7	mm	1125			1125	
4.08 Towing coupling height		h10	mm	250			250	
4.09 Overall length (with fork)		l1	mm	3120			3125	
4.10 Overall length (without fork)		l2	mm	2200			2205	
4.11 Overall width		b1	mm	1120			1120	
4.12 Fork size:thickness x width x length		2A			2A			
4.13 Fork carriage, according to ISO2328		s/e/l	mm	35×100×920			40×100×920	
4.14 Distance across fork-arms, Max./Min.		b5	mm	960/200			960/200	
4.15 Ground clearance (at mast)		m1	mm	100			100	
4.16 Ground clearance (center of wheelbase)		m2	mm	95			95	
4.17 Right angle stacking aisle width for pallet 1000x1200mm crossways		Ast	mm	3575			3580	
4.18 Right angle stacking aisle width for pallet 800x1200mm lengthways		Ast	mm	3770			3775	
4.19 Min. outside turning radius		Wa	mm	1920			1920	
Performance data								
5.01 Travel speed (laden/unladen)			km/h	14.5/15		12/13		
5.02 Lift speed (laden/unladen)			m/s	0.320/0.440	0.290/0.440	0.290/0.400	0.270/0.400	0.260/0.400
5.03 Lowering speed (laden/unladen)			m/s	0.400/0.400		0.400/0.400		
5.04 Max.drawbar pull (laden)			N	10200/9700	10200/9800	10200/9700	10200/9800	11000/10700
5.05 Max.gradeability (laden/unladen)			%	17/27	15/26	15/23	15/22	15/25
5.06 Acceleration time(10 m)(laden/unladen)			s	5.5/5.2	5.6/5.3	6.0/5.7	6.1/5.8	5.6/5.2
Battery								
6.01 Battery voltage/Capacity			V/Ah	80/150		80/125		80/150
6.02 Battery weight			kg	180		163		180
Motor and controller								
7.01 Driving motor powering (S2-60min)			kW	8		8		
7.02 Lifting motor powering (S3-15%)			kW	10.6		10.6		
7.03 Driving motor controlling mode		MOSFET/AC						
7.04 Lifting motor controlling mode		MOSFET/AC						
Addition data								
8.01 Service brake/Parking brake		Hydraulic/Mechanical						
8.02 Operating pressure for attachments			Mpa	16				

Manufacturer and Technical Data(Tabulation 2)

Characteristics		CPD20 CPD25 CPD20 CPD25 CPD30 CPD35 CPD38															
1.01 Manufacturer		CHL PREMIUM															
1.02 Model		CPD20		CPD25		CPD20		CPD25		CPD30		CPD35		CPD38			
1.03 Configuration number		A3LiH4-M		A7LiH4-S		A3LiH4-M		A7LiH4-S		A7LiH4-S		A7LiH4-S		A7LiH4-S			
1.04 Rated capacity		Q	kg	2000	2500	2000	2500	3000	3500	3000	3500	3800					
1.05 Load center distance		c	mm	500													
1.06 Power mode		Lithium battery															
1.07 Driving mode		Seated															
1.08 Front overhang		x	mm	460		477		482		477		482		482			
1.09 Wheelbase		y	mm	1660		1750		1750		1750		1780		1780			
Weight																	
2.01 Total weight (with/without battery)			kg	3585/3395	3925/3735	3540/3375	3880/3715	4550/4310	4860/4620	4500/4290	4810/4600	5240/5000					
2.02 Axle load (laden,front/rear)			kg	4970/615	5790/635	4940/600	5760/620	6750/800	7630/730	6710/790	7590/720	8150/890					
2.03 Axle load (unladen,front/rear)			kg	1750/1835	1780/2145	1720/1820	1750/2130	2050/2500	2110/2750	2010/2490	2070/2740	2220/3020					
Tyres																	
3.01 Tyre type		Pneumatic tyre					Front Pneumatic tyre/Rear Solid tyre										
3.02 Tyre size,front		7.00-12-14PR					28×9-15-14PR										
3.03 Tyre size,rear		18×7-8-14PR					18×7-8										
3.04 Wheels, number front/rear (x=driven wheels)		2/2					2/2										
3.05 Tread, front		b10	mm	970					1000					1080			
3.06 Tread, rear		b11	mm	960					970					970			
Dimensions																	
4.01 Mast tilt angle (forward/backward)		α/β	°	6/10					6/10								
4.02 Height (mast lowered)		h1	mm	2000					2070					2120			
4.03 Free lifting height		h2	mm	165					155					160			
4.04 Lifting height (standard)		h3	mm	3000					3000								
4.05 Max. height, extended (with backrest)		h4	mm	4320					4217								
4.06 Height of overhead guard		h6	mm	2170					2180					2185			
4.07 Seat height relating to SIP (to ground)		h7	mm	1154					1164								
4.08 Towing coupling height		h10	mm	300					310								
4.09 Overall length (with fork)		l1	mm	3354	3504	3354	3504	3637	3642	3637	3642	3682					
4.10 Overall length (without fork)		l2	mm	2434					2567					2572			
4.11 Overall width		b1	mm	1180					1260					1392			
4.12 Fork size:thickness x width x length		2A															
4.13 Fork carriage, according to ISO2328		s/e/l	mm	40×122×920		40×122×1070		40×122×920		40×122×1070		45×125×1070		50×125×1070		50×125×1070	
4.14 Distance across fork-arms, Max./Min.		b5	mm	1030/250					1060/250								
4.15 Ground clearance (at mast)		m1	mm	100					110					125			
4.16 Ground clearance (center of wheelbase)		m2	mm	125					135					140			
4.17 Right angle stacking aisle width for pallet 1000x1200mm crossways		Ast	mm	3753					3912					3917			
4.18 Right angle stacking aisle width for pallet 800x1200mm lengthways		Ast	mm	3953					4115					4117			
4.19 Min. outside turning radius		Wa	mm	2140					2235					2270			
Performance data																	
5.01 Travel speed (laden/unladen)			km/h	14.5/15			12/13			14.5/15			12/13				
5.02 Lift speed (laden/unladen)			m/s	0.320/0.440	0.290/0.440	0.290/0.400	0.270/0.400	0.320/0.440	0.290/0.440	0.290/0.400	0.270/0.400	0.270/0.400					
5.03 Lowering speed (laden/unladen)			m/s	0.360/0.460				0.400/0.400									
5.04 Max.drawbar pull (laden)			N	13600/13000	14000/13300	13600/13000	14000/13300	16300/15800	17000/16600	16300/16000	16900/15900	16800/16200					
5.05 Max.gradeability (laden/unladen)			%	17/26	15/25	15/25	15/25	17/26	15/23	15/25	15/22	15/20					
5.06 Acceleration time(10 m)(laden/unladen)			s	5.9/5.0	6.1/5.0	6.0/5.3	6.2/5.3	5.7/5.1	6.1/5.2	5.8/5.3	6.3/5.4	6.2/5.2					
Battery																	
6.01 Battery voltage/Capacity			V/Ah	80/202		80/150		80/250		80/202		80/250					
6.02 Battery weight			kg	190		165		240		210		240					
Motor and controller																	
7.01 Driving motor powering (S2-60min)			kW	11					15								
7.02 Lifting motor powering (S3-15%)			kW	12					16								
7.03 Driving motor controlling mode		MOSFET/AC															
7.04 Lifting motor controlling mode		MOSFET/AC															
Addition data																	
8.01 Service brake/Parking brake		Hydraulic/Mechanical															
8.02 Operating pressure for attachments			Mpa	16													

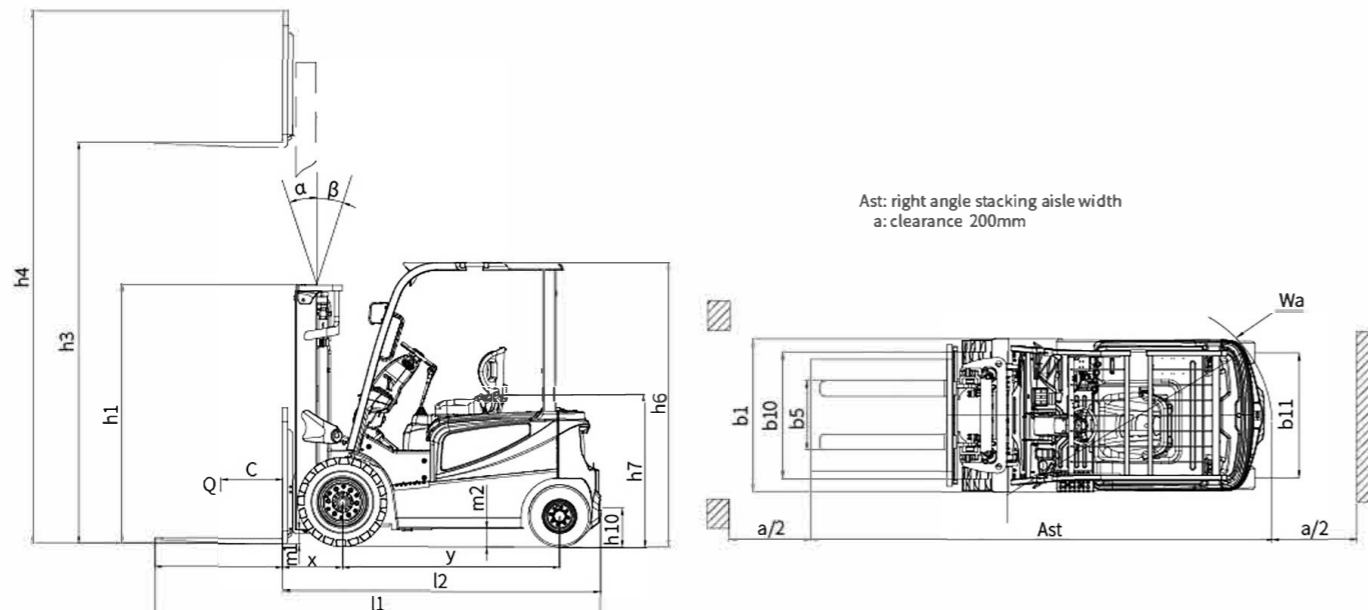

Load curve

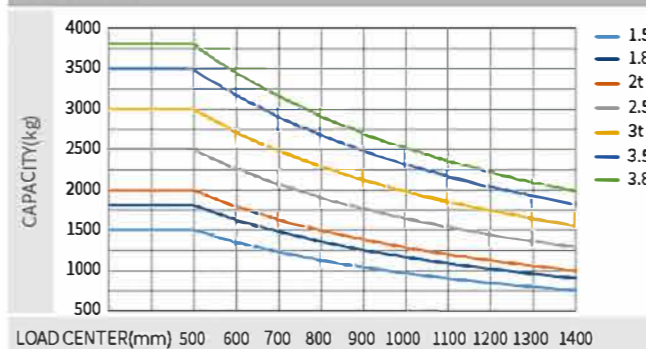

Note:

The vertical axis stands for load capacity and the horizontal axis stands for load center which is calculated from the front surface of the forks to the gravity of the standard load. The standard load means a cubic with 1000mm edge length. When mast is tilted forward, using non-standard forks or loading large goods, the load capacity will be reduced. The load capacity of standard mast at different load center can be known from this load chart.

Lithium battery		CHL premium								CATL										
Battery brand		80V/125Ah	80V/150Ah	80V/202Ah	80V/250Ah	80V/280Ah	80V/404Ah	80V/560Ah	80V/125Ah	80V/150Ah	80V/173Ah	80V/202Ah	80V/228Ah	80V/271Ah	80V/302Ah	80V/346Ah	80V/404Ah	80V/456Ah	80V/542Ah	80V/604Ah
1.5-1.8t S	●	○	○	○	○	○	○	○	○	○	○	○	○	○	○	○	○	○	○	○
1.5-1.8t M	○	●	○	○	○	○	○	○	○	○	○	○	○	○	○	○	○	○	○	○
2t (X) S	○	○	○	○	○	○	○	○	○	○	○	○	○	○	○	○	○	○	○	○
2-2.5t S	○	○	○	○	○	○	○	○	○	○	○	○	○	○	○	○	○	○	○	○
2-2.5t M	○	○	○	○	○	○	○	○	○	○	○	○	○	○	○	○	○	○	○	○
3-3.5t S	○	○	○	○	○	○	○	○	○	○	○	○	○	○	○	○	○	○	○	○
3-3.5t M	○	○	○	○	○	○	○	○	○	○	○	○	○	○	○	○	○	○	○	○
3.8t S	○	○	○	○	○	○	○	○	○	○	○	○	○	○	○	○	○	○	○	○
Heating at low Temperature	●																			

Note: ● standard; ○ optional; — non-configurable.

Charger		Model	
Model		D80V100AL1-438	
Wiring type		Three-phase four-wiring type	
Power of charger	KVA	10	
Air switch model of Upper level power	A	32	
Input voltage range	Vac	380±15%	
Input current	A	<20A	
Output current	A	5~100	
Protection level		For indoor use	
Working ambient temperature	°C	-20~+45	
Plugs and sockets		REMA320	
Charger		Full charging time=required chaging capacity/charging current+0.2h For example: the battery capacity is 80V/250Ah, and the discharging state is alarmed by instrument, The charger is 100A, thus the full charging time is 250*0.9/100+0.2≈2.45h	

Lithium Battery Advantages

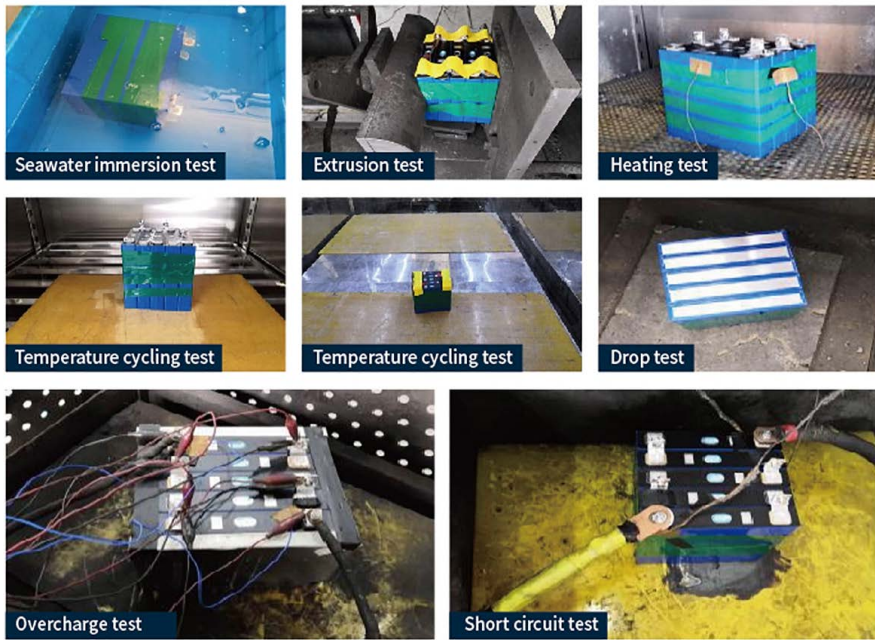

- The truck selects mature and economical square iron phosphate lithium battery core and module used by large numbers of commercial vehicles;
- The module adopts aluminum alloy plate frame, which is firm, light in weight and has good heat dissipation effect;
- Fast charging: fast charging makes truck gapless operation possible, and it can be filled in 2 hours;
- High efficiency and safety: The charging and discharging efficiency is up to 98%, and temperature of thermal runaway is over 600 °C;
- Low temperature adaptability: Standard configuration of heating function ensures normal operation of low temperature environment;
- Long service life: the normal charging and discharging cycles is more than 3000 times or 5 years, and capacity retention rate is more than 75%;
- Maintenance free: the battery does not need manual maintenance and does not need to add distilled water electrolyte;
- Green and clean: no pollution and zero emission.

Smart fleet management system (domestic basic edition)

Vehicle positioning	Statistical form
Remote diagnosis	Vehicle management
Remote monitoring	Identification recognition (optional)
Maintenance reminder	Weight management (optional)
Battery management	Collision management (optional)



1.5t/1.8t/2t(E) Mast parameters																
Mast type	Mast model	Max lifting height (mm)	Load capacity (lode center 500mm)(kg)			Height (mm) (mast lowered)		Free lift (with backrest) (mm)		Service weight (kg)				Mast tilt angle α/β (°)		
			1.5t	1.8t	2t(E)	1.5-1.8t	2t(E)	1.5-1.8t	2t(E)	1.5t-S	1.8t-M	1.8t-M	2t(E)	1.5-1.8t	2t(E)	
2-stage standard Mast	M200	2000	1500	1800	2000	1495	1495	155	155	2771	2791	2886	2905	3036	6/8	6/8
	M250	2500	1500	1800	2000	1745	1745	155	155	2803	2823	2918	2938	3058	6/8	6/8
	M300	3000	1500	1800	2000	1995	1995	155	155	2835	2855	2950	2970	3100	6/8	6/8
	M330	3300	1500	1800	2000	2145	2145	155	155	2854	2874	2969	2989	3119	6/8	6/8
	M350	3500	1500	1800	2000	2245	2245	155	155	2867	2887	2982	3002	3132	6/8	6/6
	M370	3700	1500	1800	2000	2345	2345	155	155	2880	2900	2995	3015	3145	6/6	6/6
	M400	4000	1500	1800	2000	2545	2545	155	155	2928	2948	3043	3063	3193	6/6	6/6
	M425	4250	1500	1800	1950	2670	2670	155	155	2945	2965	3060	3080	3210	6/6	6/6
	M450	4500	1450	1650	1750	2795	2795	155	155	2961	2981	3076	3096	3226	6/6	6/6
	M500	5000	1200	1400	1500	3045	3045	155	155	2993	3013	3108	3128	3258	6/6	6/6
	M550	5500	1000	1100	1200	3345	3345	155	155	3055	3075	3170	3190	3320	3/6	3/6
	M600	6000	800	900	1000	3595	3595	155	155	3087	3107	3202	3222	3352	3/6	3/6
2-stage full free mast	ZM200	2000	1500	1800	2000	1495	1495	485	485	2820	2840	2935	2955	3085	6/8	6/8
	ZM250	2500	1500	1800	2000	1745	1745	735	735	2852	2872	2967	2987	3117	6/8	6/8
	ZM300	3000	1500	1800	2000	1995	1995	985	985	2886	2906	3001	3021	3151	6/8	6/8
	ZM330	3300	1500	1800	2000	2145	2145	1135	1135	2908	2928	3023	3043	3173	6/8	6/8
	ZM350	3500	1500	1800	2000	2245	2245	1235	1235	2923	2943	3038	3058	3188	6/8	6/8
	ZM370	3700	1500	1800	2000	2345	2345	1335	1335	2935	2955	3050	3070	3200	6/6	6/6
	ZM400	4000	1500	1800	2000	2545	2545	1535	1535	2983	3003	3098	3118	3248	6/6	6/6
	ZM425	4250	1500	1800	1950	2670	2670	1660	1660	3002	3022	3117	3137	3267	6/6	6/6
	ZM450	4500	1450	1650	1750	2795	2795	1785	1785	3021	3041	3136	3156	3286	6/6	6/6
	ZM500	5000	1200	1400	1500	3045	3045	2035	2035	3055	3075	3170	3190	3320	3/6	3/6
	ZM550	5500	1000	1100	1200	3345	3345	2335	2335	3116	3136	3231	3251	3381	3/6	3/6
	ZM600	6000	800	900	1000	3595	3595	2585	2585	3150	3170	3265	3285	3415	3/6	3/6
3-stage full free mast	ZSM360	3600	1500	1800	2000	1790	1790	785	785	2934	2954	3049	3069	3199	6/6	6/6
	ZSM400	4000	1500	1800	2000	1925	1925	920	920	2958	2978	3073	3093	3223	6/6	6/6
	ZSM435	4350	1450	1650	1850	2040	2040	1035	1035	2983	3003	3098	3118	3248	6/6	6/6
	ZSM450	4500	1500	1750	1750	2090	2090	1085	1085	2994	3014	3109	3129	3259	6/6	6/6
	ZSM470	4700	1450	1650	1850	2160	2160	1155	1155	3010	3010	3105	3125	3255	6/6	6/6
	ZSM480	4800	1350	1550	1650	2190	2190	1185	1185	3017	3037	3132	3152	3282	6/6	6/6
	ZSM500	5000	1200	1400	1500	2290	2290	1285	1285	3038	3058	3153	3173	3303	6/6	6/6
	ZSM540	5400	1000	1100	1200	2415	2415	1410	1410	3064	3084	3179	3199	3329	3/6	3/6
	ZSM600	6000	800	900	1000	2640	2640	1635	1635	3136	3156	3251	3271	3401	3/6	3/6
	ZSM650	6500	1100	1250	1350	2840	2840	1835	1835	3174	3194	3289	3309	3439	3/6	3/6
	ZSM700	7000	900	950	1000	3025	3025	2025	2025	3212	3232	3327	3347	3477	3/6	3/6

Note: *Indicates the rated load capacity of the front wheel with twin tyres; 2t (E) indicates that the truck type is CPD20-ATXUH4-S; When the front wheels of 1.5-1.8t are twin tyres (pneumatic tyres) and twin tyres (solid tyres), the service weight is increased by 58kg and 104kg respectively according to the table data.
2-stage full free mast: 1.5-2t(E): When there is no backrest, the free lifting height increases by 379mm.
3-stage full free mast: 1.5-2t(E): When there is no backrest, the free lifting height increases by 484mm.

2t/2.5t Mast parameters																
Mast type	Mast model	Max lifting height (mm)	Load capacity (lode center 500mm)(kg)			Height (mm) (mast lowered)		Free lift (with backrest) (mm)		Service weight (kg)				Mast tilt angle α/β (°)		
			2t	2.5t	2t(E)	2-2.5t	2-2.5t	2t-S	2t-M	2.5t-S	2.5t-M	2-2.5t	2-2.5t			
2-stage standard Mast	M200	2000	2000	2500	1500	1500	150	150	3460	3505	3800	3845	4140	6/10	6/10	
	M250	2500	2000	2500	1750	1750	150	150	3508	3553	3848	3893	4188	6/10	6/10	
	M300	3000	2000	2500	2000	2000	150	150	3540	3585	3880	3925	4220	6/10	6/10	
	M330	3300	2000	2500	2150	2150	150	150	3580	3625	3920	3965	4260	6/10	6/10	
	M350	3500	2000	2500	2250	2250	150	150	3599	3644	3939	3984	4275	6/10	6/10	
	M370	3700	2000	2500	2350	2350	150	150	3615	3660	3955	4000	4300	6/6	6/6	
	M400	4000	2000	2500	2550	2550	150	150	3687	3732	4027	4072	4367	6/6	6/6	
	M425	4250	1950	2450	2450	2675	2675	150	150	3711	3756	4051	4096	4391	6/6	6/6
	M450	4500	1900	2400	2400	2800	2800	150	150	3733	3778	4073	4118	4413	6/6	6/6
	M500	5000	1850	2350	2350	3050	3050	150	150	3777	3822	4117	4162	4457	6/6	6/6
	M550	5500	1450	1950	1950	3350	3350	150	150	3868	3913	4208	4253	4548	3/6	3/6
	M600	6000	1200	1700	1700	3600	3600	150	150	3913	3958	4253	4298	4593	3/6	3/6
2-stage full free mast	ZM200	2000	2000	2500	1500	1500	496	496	3727	3772	4067	4112	4407	6/10	6/10	
	ZM250	2500	2000	2500	1750	1750	746	746	3793	3838	4133	4178	4473	6/10	6/10	
	ZM300	3000	2000	2500	2000	2000	996	996	3860	3905	4200	4245	4540	6/10	6/10	
	ZM330	3300	2000	2500	2150	2150	1146	1146	3900	3945	4240	4285	4580	6/10	6/10	
	ZM350	3500	2000	2500	2250	2250	1246	1246	3927	3972	4267	4312	4607	6/10	6/10	
	ZM370	3700	2000	2500	2350	2350	1346	1346	3953	3998	4293	4338	4633	6/6	6/6	
	ZM400	4000	2000	2500	2550	2550	1546	1546	4044	4089	4384	4429	4724	6/6	6/6	
	ZM425	4250	1950	2450	2450	2675	2675	1671	1671	4077	4122	4417	4462	4759	6/6	6/6
	ZM450	4500	1900	2400	2400	2800	2800	1796	1796	4110	4155	4450	4495	4790	6/6	6/6
	ZM500	5000	1850	2350	2350	3050	3050	2046	2046	4177	4222	4517	4562	4857	6/6	6/6
	ZM550	5500	1450	195												

3t/3.5t/3.8t Mast parameters																	
Mast type	Mast model	Max.lifting height (mm)	Load capacity (load center 500mm)(kg)			Height (mast lowered) (mm)			Free lift (with backrest) (mm)			Service weight (kg)				Mast tilt angle/β(°)	
			3t	3.5t	3.8t	3t	3.5t	3.8t	3t	3.5t	3.8t	3t-S	3t-M	3.5t-S	3.5t-M		3.8t-S
2-stage standard Mast	M200	2000	3000	3500	3800	1570	1620	1680	155	160	160	4404	4454	4704	4754	5134	6/10
	M250	2500	3000	3500	3800	1820	1870	1930	155	160	160	4452	4502	4757	4807	5187	6/10
	M300	3000	3000	3500	3800	2070	2120	2180	155	160	160	4500	4550	4810	4860	5240	6/10
	M330	3300	3000	3500	3800	2220	2270	2330	155	160	160	4529	4579	4842	4892	5272	6/10
	M350	3500	3000	3500	3800	2320	2370	2430	155	160	160	4548	4598	4863	4913	5293	6/10
	M370	3700	3000	3300	3800	2420	2470	2530	155	160	160	4567	4617	4884	4934	5314	6/6
	M400	4000	2850	3150	3700	2620	2670	2730	155	160	160	4647	4697	4968	5018	5398	6/6
	M425	4250	2750	3050	3550	2745	2795	2855	155	160	160	4671	4721	4994	5044	5424	6/6
	M450	4500	2600	2900	3400	2870	2920	2980	155	160	160	4695	4745	5021	5071	5451	6/6
	M500	5000	2300	2600	3100	3120	3170	3230	155	160	160	4743	4793	5074	5124	5504	6/6
2-stage full free mast	M550	5500	1950	2300	2700	3420	3470	3530	155	160	160	4841	4891	5178	5228	5608	6/6
	M600	6000	1300	1650	2100	3670	3720	3780	155	160	160	4889	4939	5231	5281	5661	6/6
	ZM200	2000	3000	3500	3800	1570	1620	1680	340	443	503	4432	4482	4728	4778	5158	6/10
	ZM250	2500	3000	3500	3800	1820	1870	1930	590	693	753	4482	4532	4781	4831	5211	6/10
	ZM300	3000	3000	3500	3800	2070	2120	2180	840	943	1003	4532	4582	4835	4885	5265	6/10
	ZM330	3300	3000	3500	3800	2220	2270	2330	990	1093	1153	4564	4614	4868	4918	5298	6/10
	ZM350	3500	3000	3500	3800	2320	2370	2430	1090	1193	1253	4584	4634	4889	4939	5319	6/10
	ZM370	3700	3000	3200	3800	2420	2470	2530	1190	1293	1353	4604	4654	4910	4960	5340	6/6
	ZM400	4000	2850	3200	3700	2620	2670	2730	1390	1493	1553	4682	4732	4990	5040	5420	6/6
	ZM425	4250	2750	3050	3550	2745	2795	2855	1515	1618	—	4708	4758	5017	5067	—	6/6
3-stage full free mast	ZM450	4500	2500	2850	—	2870	2920	2980	1640	1743	—	4736	4786	5046	5096	—	6/6
	ZM500	5000	2100	2450	—	3120	3170	3230	1890	1993	—	4790	4840	5102	5152	—	6/6
	ZM550	5500	1400	1750	—	3420	3470	3530	2190	2293	—	4889	4939	5205	5255	—	6/6
	ZM600	6000	1300	1650	—	3670	3720	3780	2440	2543	—	4942	4992	5261	5311	—	6/6
	ZSM360	3600	2850	3250	3800	1870	1870	1930	640	640	693	4643	4693	4921	4971	5354	6/6
	ZSM400	4000	2750	3100	3700	2020	2020	2055	790	790	843	4684	4734	4962	5012	5395	6/6
	ZSM435	4350	2550	2950	3500	2120	2120	2180	890	890	943	4713	4763	4991	5041	5424	6/6
	ZSM450	4500	2450	2850	3400	2170	2170	2230	940	940	993	4728	4778	5006	5056	5439	6/6
	ZSM470	4700	2400	2800	3300	2230	2230	2295	1000	1000	1053	4746	4796	5024	5074	5457	6/6
	ZSM480	4800	2350	2750	3300	2270	2270	2330	1040	1040	1093	4756	4806	5034	5084	5467	6/6
ZSM500	5000	2100	2550	3000	2370	2370	2430	1140	1140	1193	4783	4833	5061	5111	5494	6/6	
ZSM540	5400	1950	2450	3150	2470	2470	2555	1240	1240	1293	4813	4863	5091	5141	5524	6/6	
ZSM600	6000	1350	1800	2400	2670	2670	2780	1440	1440	1493	4917	4967	5103	5153	5628	6/6	
ZSM650	6500	950	1400	2000	2870	2870	—	1640	1640	—	4972	5022	5250	5300	—	6/6	
ZSM700	7000	1800	2000	—	3045	3045	—	1815	1815	—	5022	5072	5300	5350	—	6/6	

Note: *Indicates the rated load capacity of the front wheel with twin tyres; When the front wheels of 3.3.5t are twin tyres (pneumatic tyres) and twin tyres (solid tyres), the service weight is increased by 140kg and 208kg respectively according to the table data; When the front wheels of 3.8t are twin tyres (pneumatic tyres) and twin tyres (solid tyres), the service weight is increased by 103kg and 251kg respectively according to the table data
 2-stage full free mast: 3t: When there is no backrest, the free lifting height increases by 477mm; 3.5t-3.8t: When there is no backrest, the free lifting height increases by 407mm.
 3-stage full free mast: 3t: When there is no backrest, the free lifting height increases by 427mm; 3.5-3.8t: When there is no backrest, the free lifting height increases by 407mm.

Optional item	Model	S	
Basic items	Pneumatic tyre*	●	
	Solid tyre	○	
	Single tyre (front wheel)	●	
	Twin tyre (front wheel)**	○	
	Two piece valve	●	
	Three or four piece valve	○	
	Basic type: 3M lifting height mast	●	
	Other type and other height seriesmast***	○	
	Standard series fork	●	
	Non standard series forks and attachments	○	
Safety items	Standard exterior color (blue grey + red)	●	
	Other exterior colors (customized)	○	
	Turning speed limit	○	
	Reversing armrest with horn switch	○	
	Overspeed 5km / h alarm	○	
	Overspeed 8km / h alarm	○	
	Overspeed 10km / h alarm	○	
	Travelling + lifting + tilting + equipped with OPS function (without lowering)	●	
	Full set of OPS functions	○	
	Seat belt switch	○	
Comfort items	Multi way valve overload	●	
	Dry powder fire extinguisher (0.5kg)	○	
	Dry powder fire extinguisher (2kg)	○	
	Carbon dioxide fire extinguisher (2kg)	○	
	Reversing buzzer	●	
	Reversing Chinese speaker	○	
	No universal key	●	
	With universal key	○	
	Electronic lifting upper buffer	○	
	Central wide-angle rearview mirror	●	
Cab / Windshield / Air conditioner / Heater	Both side rear-view mirrors + center wide-angle rear-view mirror	○	
	Reversing radar (4 probes)	○	
	Reversing image (1 Camera + 4 radar probes)	○	
	Semi enclosed seat	●	
	Fully suspended seat	○	
	Instrument panel with 1 USB interface (5V / 1A)	○	
	Steering wheel starts steering	○	
	Synchronous steering	○	
	Steering wheel with handle ball	●	
	Steering wheel without handle ball	○	
Non standard overhead guard	Electric fan	○	
	panel mounted cab (including fan + wiper)	○	
	Heater	○	
	Single cooling air conditioner	○	
	Single cooling air conditioner + heater	○	
	Front windshield (including wiper)	○	
	Rear windshield	○	
	Top windshield (excluding fan)	○	
	50mm increased of overhead guard height	○	
	50mm reduced of overhead guard height	○	
Lights	Overhead guard (with protective net)	○	
	LED rear work light (1)	○	
	Rear LED red / Blue spotlight (1)	○	
	Rear and lateral red / blue bar lights	○	
	Fixed LED flashing warning light	○	
	Fixed LED rotary warning lamp	○	
	Fixed LED rotary buzzer warning light	○	
	Others	Metric thread	●
		Tilt cylinder jacket	○
		Steering cylinder jacket	○
REMA 320 charging port		●	
Onboard charger		○	
FICS standard type (for China)	○		

Note:
 ●*Standard ; ○*Optional ;
 Some non-standard options need to be customized. Please consult local sales personnel or product development technicians before purchasing.
 *3-3.8t rear wheel is equipped with solid tyre as standard.
 **The small 2t truck is not equipped with twin tyres.
 ***There are restrictions on the type and height of small 2t and 3.8t mast. See the table of mast parameters for details.